

HILLIARD

RAINIER CHANDELIER



DESIGN:

The Rainier chandelier is an elegant balance of weighted material and weightless orientation. Each selenite stone is masterly chiseled to a cylindrical shape showcasing its raw, earthy texture. The fixture is skillfully cradled in a cast bronze cylinder, hand finished in a fine hammered texture.

FINISHES SHOWN:

Hand carved selenite stone and hammered matte black bronze, additional finishes available.

HILLIARD

RAINIER CHANDELIER

DIMENSIONS: Each Pendant: 27 x 4 IN
69 x 10 CM

Canopy: 16.5 x 1 IN
42 x 2.5 CM

Height determined by designer.
Over 48" overall height includes
additional charges.

WEIGHT: 3 PENDANTS APPROX 115 LBS
4 PENDANTS APPROX 140 LBS
5 PENDANTS APPROX 175 LBS

VOLTAGE: 120v standard / 240 available

UL DAMP LISTED/ CE AVAILABLE

J-BOX REQUIREMENT: Reinforced

LAMPING PER PENDANT: (2) 6W DIMMABLE LED BULBS
PER PENDANT
600 LUMENS EACH - 2700k or 3000k.
120V : G9 candelabra LED
240V : G9 candelabra LED
<https://emeryallen.com/product/g9-6w/>

CA title 24- JA8 compliant

Each fixture is hand crafted, signed,
and numbered in Arcata, CA

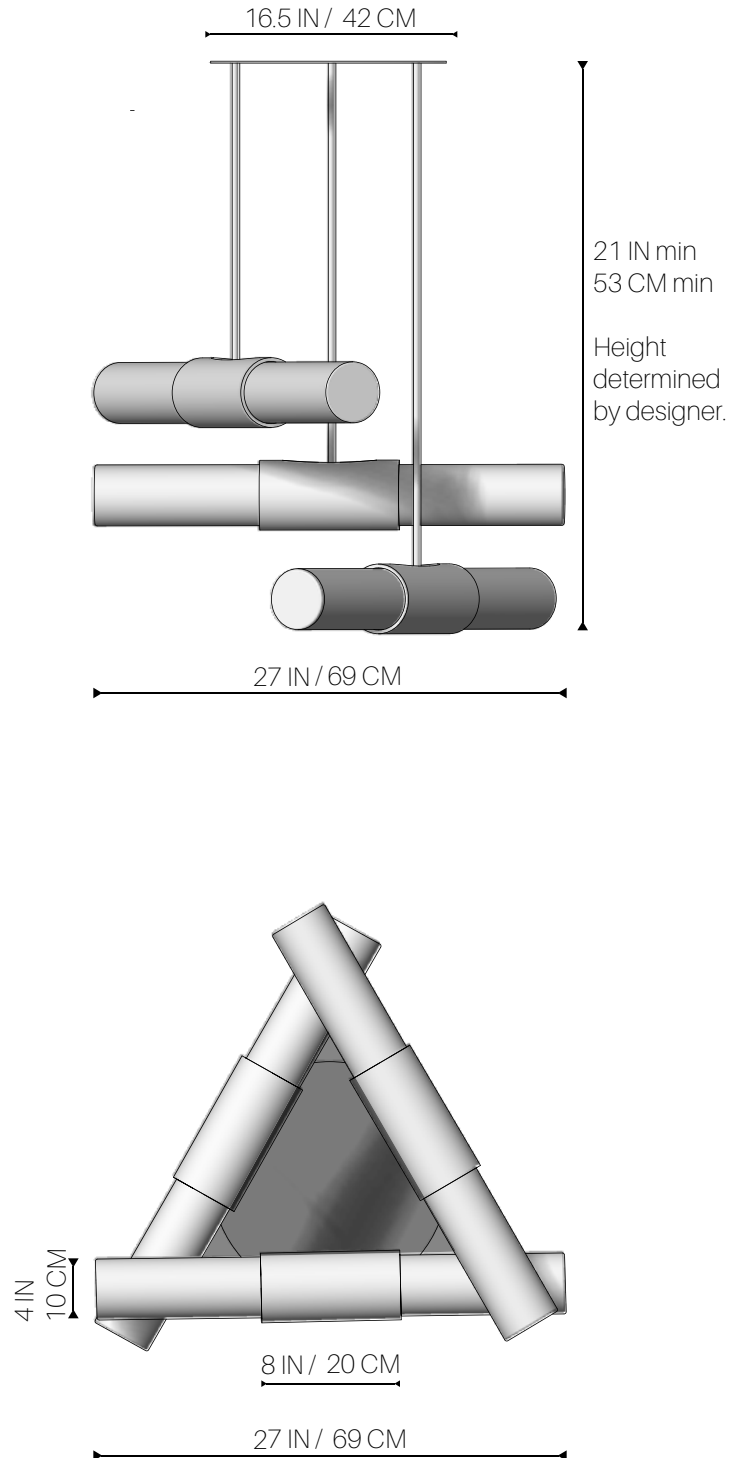

HILLIARD

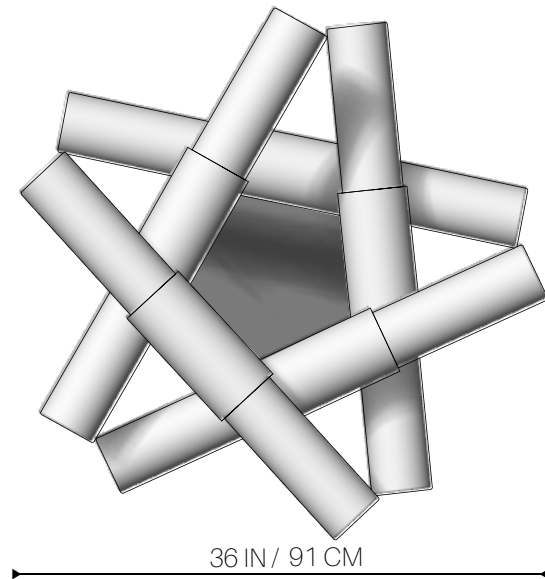
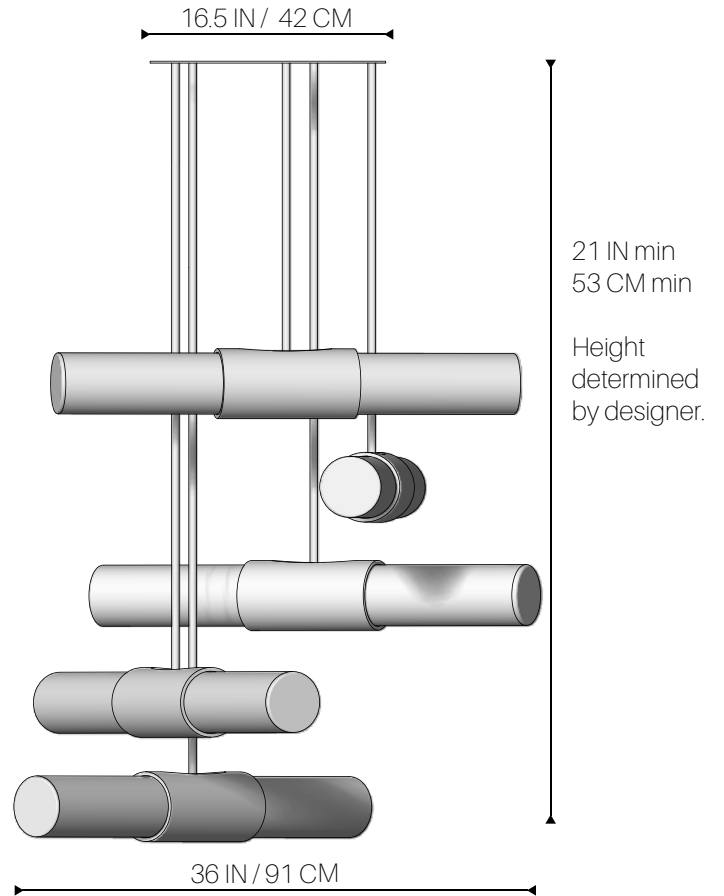
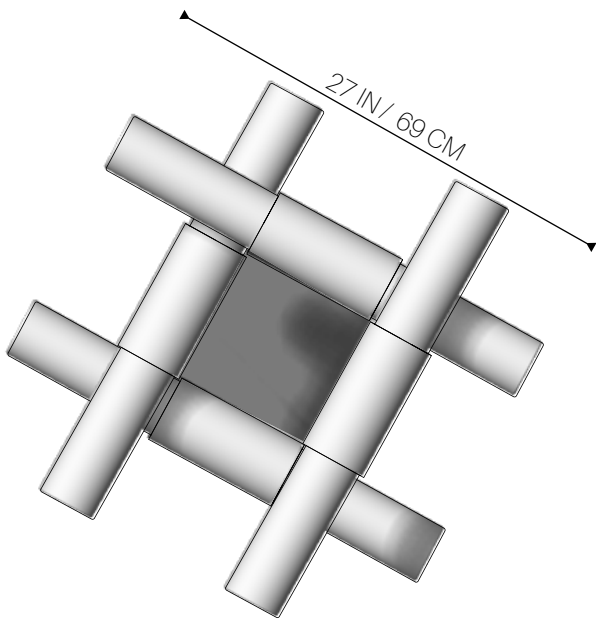
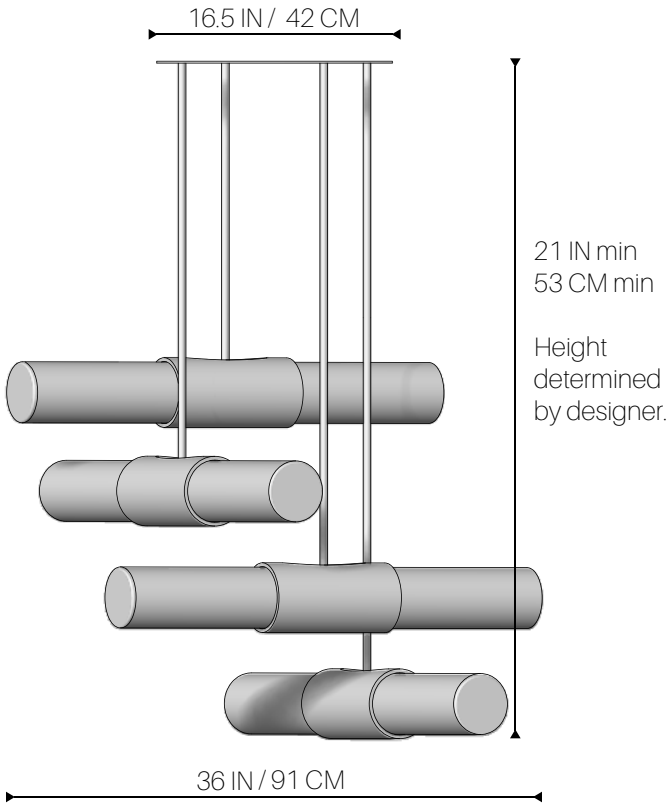

HILLIARD



CARVED SELENITE STONE
HAMMERED MATTE BLACK BRONZE

HILLIARD

STANDARD FINISHES AVAILABLE
CONTACT INFO@HILLIARDLAMPS.COM FOR CUSTOM REQUESTS

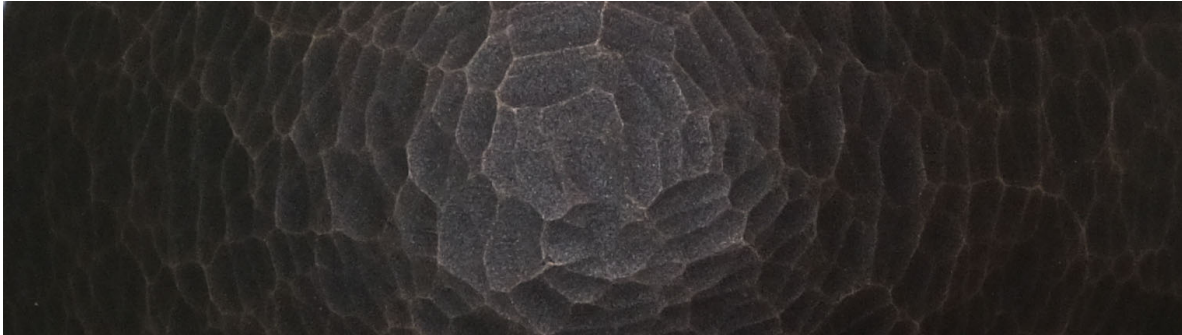

HAMMERED ANTIQUE BRONZE

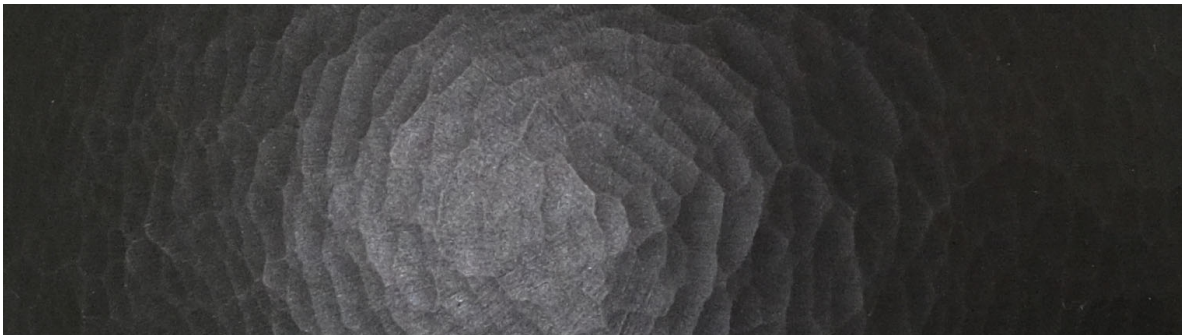

HAMMERED MATTE BLACK BRONZE



SELENITE STONE

HILLIARD

CEILING CANOPY INSTALLATION

all parts below included

